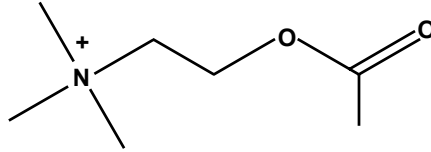
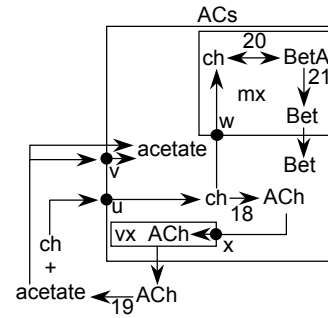

Table 4: Acetylcholine

2-(acetyloxy)-N,N,N-trimethylethanaminium⁺
 MW: 147
 Cation at physiological pH



Localization:
 ACs (enzyme immunocytochemistry)



Metabolism: enzyme	EC	map	site
18 cholineacetyl transferase	2.3.1.6	B8	c pm
19 acetylcholinesterase	3.1.1.7	B8	c pm ecm
20 choline dehydrogenase	1.1.99.1	B8	mim
21 BetA dehydrogenase	1.2.1.8	B8	mx

reactants	→	products
acetyl-CoA + ch	→	CoA + ACh
ACh	→	ch + acetate
ch	↔	BetA
BetA	→	Bet

Transporters	TC	Localization
plasma membrane		
u CHT1	2.A.21.8.1	Φ ACs, PRs
v MCT1	2.A.1.13.1	?
mitochondria		
w ch transporter	na	mim
synaptic vesicles		
x VAcHT	2.A.1.2.13	Φ brain vm

Receptors: Ionotropic	TC	Subunits	Dominant Localization
nAChR	1.A.9.1.1	α2-10, β2-4	∇Φ ACs, GCs
Receptors: Heptahelical		Subtypes	Dominant Localization
GPCR Class A mAChR Gs		M1,M3,M5	∇ BCs, ACs (M3)
GPCR Class A mAChR Gi/o		M2,4	∇ ACs, GCs

Abbreviations: see Tables 1-3

Bet: betaine
 BetA: betaine aldehyde

ch: choline
 ecm: extracellular matrix

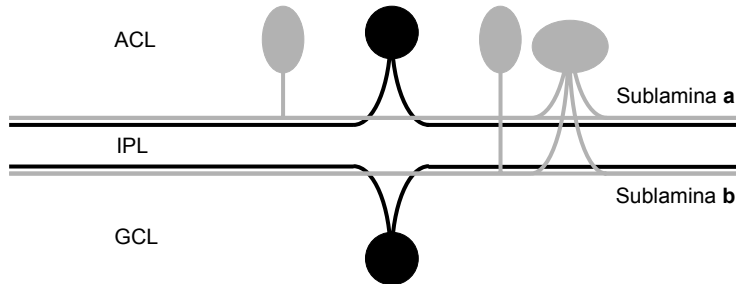

Neurons expressing the cholinergic phenotype include conventional and displaced starburst ACs in all species and, in many non-mammals, additional conventional pyriform ON, pyriform OFF, and bistratified ACs (grey) that also arborize in the two cholinergic strata.